

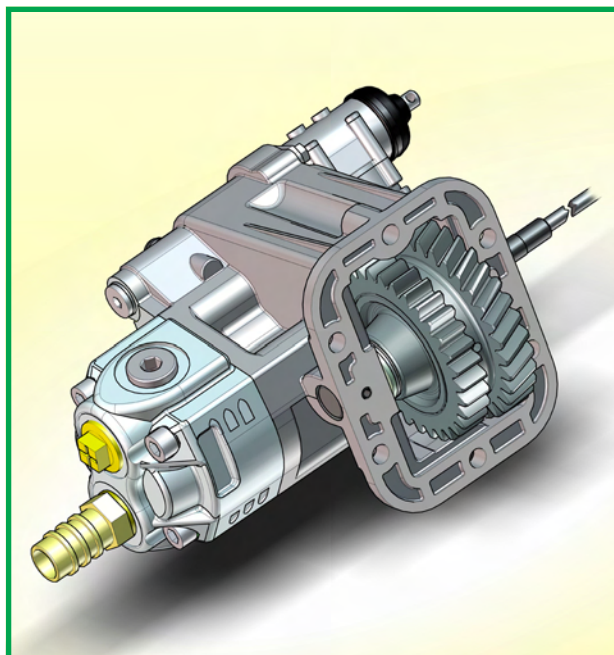

## NEW PTO SERIES 03 WITH INTEGRATED GEAR PUMP



HYDROCAR presents the new side PTO series **03** with integrated gear pump for medium-small vehicles (Iveco Daily, Renault Master, etc.), with a wide selection of pump displacements/pressures, and in electric or new mechanical version by “**TX3**” cable control.

The new PTOs series **03** has the same features as a standard PTO but with reduced overall sizes. They are also easier for the customer to fit because the gear pump is already built to the PTO. In the mechanical version, the coupling of the new **TX3** control has been designed to be turned and fitted specularly by 360° (remote control unit facing either cab or rear of the vehicle).

For more details, please contact our sales department or refer to our WebPTO program (“Main Archives” menu, “PTO” section”).

### TECHNICAL SPECIFICATIONS

PTO:	03Z1	03Z3	03Z4	03Z6	
Gearbox type:	Iveco 2825.5 Iveco 2830.5 ZF 5S200 ZF 5S270 ZF 5S300	Iveco 2840.6 ZF 6AS380 VO ZF 6AS400 VO ZF 6S380 VO ZF 6S400 VO	Iveco 2840.6 FL2011	ZF 5S400	
Torque (Nm):	120	175	170	180	
Output ratio:	0.993	0.955	1.140	0.982	
Rotation:	opposite engine				
Shift type:	- electric KES 5 - mechanical for the new cable control series TX3				
To be additionally required:	199K9250000				
On request:	- Merit switch kit code 194KSP17000 - wiring kit code 133KE008000 - bracket kit for cable control code 190ST000300				
Pump displacement ( <i>suction/delivery on head</i> ):	11cc *	16cc *	22cc *	28cc **	32cc **
Pump pressure:	280 bar	280 bar	260 bar	220 bar	190 bar
	<b>* Currently available pump versions</b>			<b>** Pump versions ON REQUEST</b>	

# NEW





### ELECTRIC PTO – OVERALL DIMENSIONS

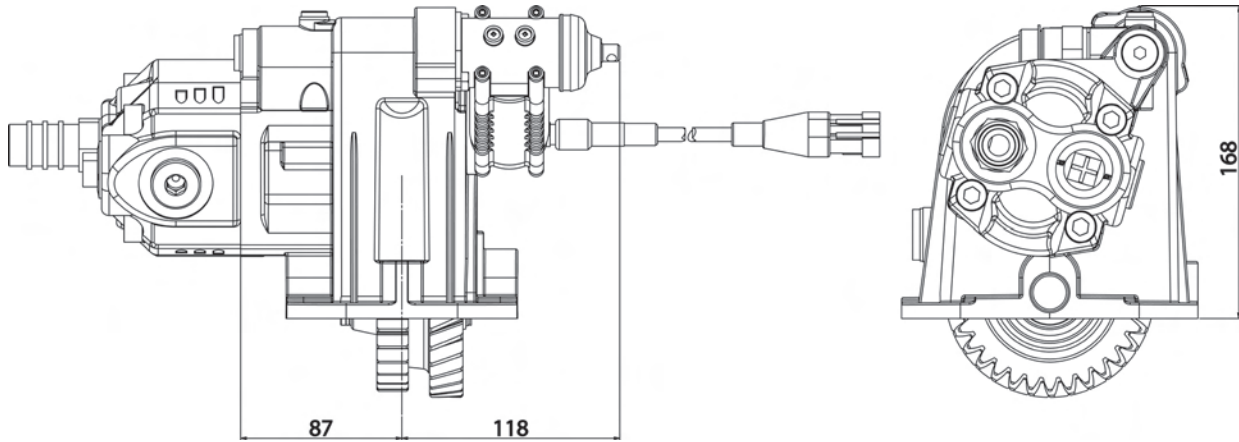

### MECHANICAL PTO – OVERALL DIMENSIONS

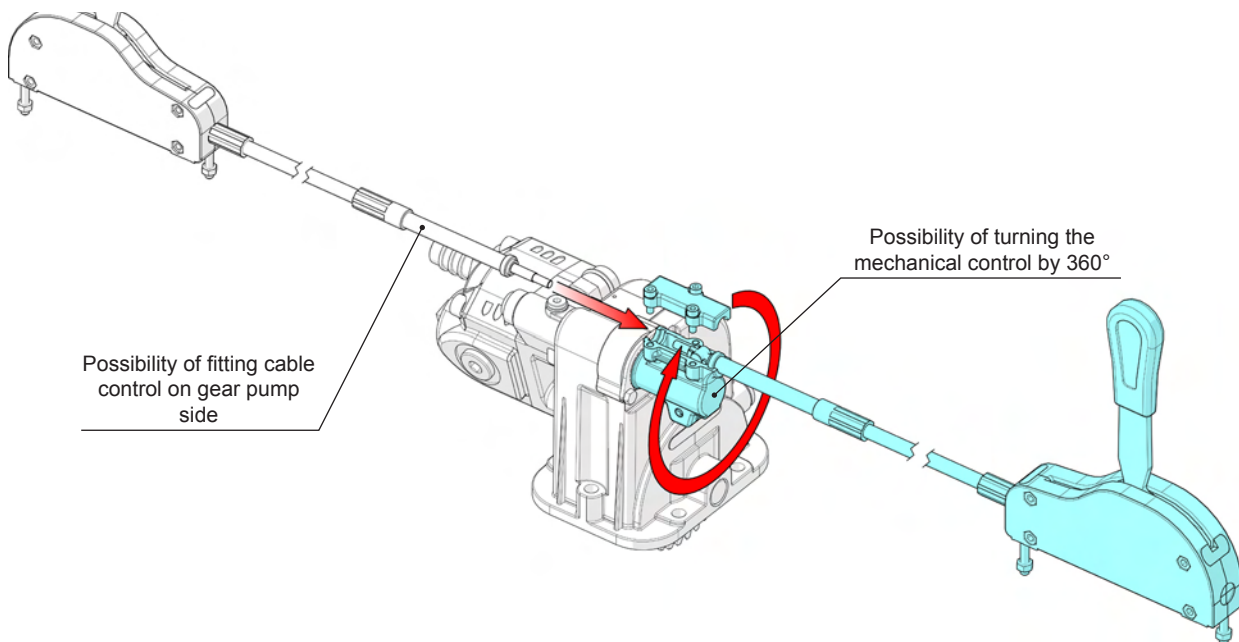
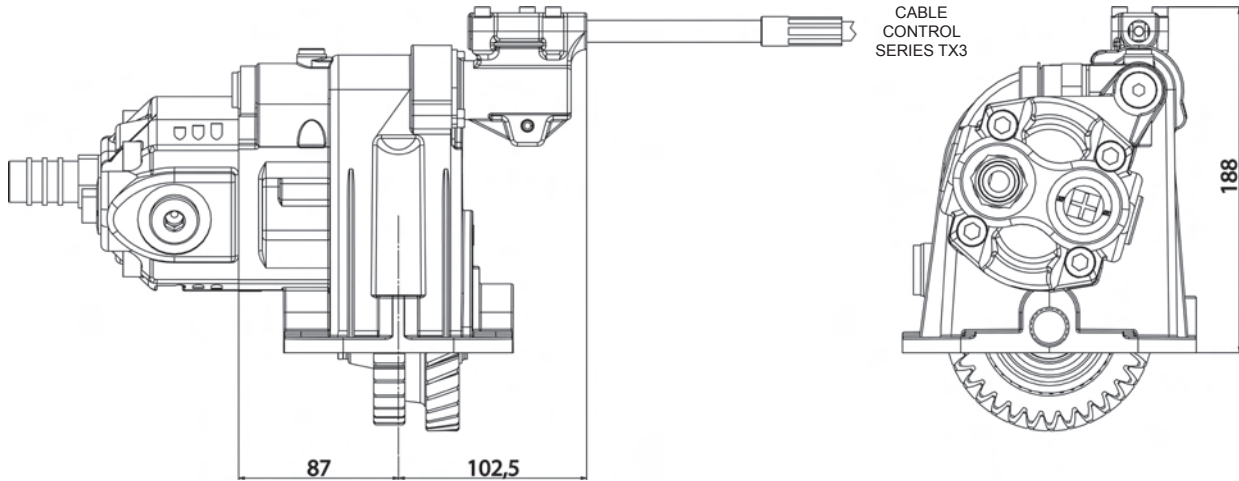

# NEW